



Series FSB 22 Mounting Pad 2-Piece

Full Port Ball Valves

1/4" - 4" (DN8 - DN100)
2000 psi (PN130)

www.valvesolution.com.au



FIRE-SAFE



ANTI-STATIC



GUARANTEE SAFETY

360° All Around Welding

In applications where economical fire-safe ball valves are required, DIE ERSTE Series FSB 22 is the first choice. The Series FSB 22 has been fire-safe approved and certified with API 607 4th edition. In addition to the general fire-safe design, Series FSB 22 has special 360° all around welding design to prevent external leakage. The end cap is welded together around the valve body, and cannot be separated permanently. The fire-safe design provides high pressure rating and higher temperature endurance.

In process industries, petroleum and flammable applications often require fire-safe equipments. For ideal fire-safe valves, DIE ERSTE offers Series FSB 22 Mounting Pad 2-Piece Fire-Safe Full Port Ball Valve 2000psi, where maximum flow capacity and minimum pressure drops are required. Series FSB 22 meets API 607 4th Edition with fire-safe design, including fire-safe lip, graphite seals, and anti-static devices. The API 607 certification is designed to test soft seat quarter turn valves, where valves are tested under high temperature condition (above 750°C) for certain period of time.

The fire-safe design is consist of three elements: fire-safe lip, graphite seals, and anti-static devices. Fire-safe lip is a precise machined metal ring to fit with the valve ball after the soft ball seat has been decomposed by high temperature heat. The fire-safe lip acts as a metal seat, and together with the floating ball pushed by downstream, the tight-shutoff secondary seal is formed even without the presence of soft ball seat. In the body connection where main body and end cap are connected, DIE ERSTE offers dual body seal to achieve non-leakage externally. DIE ERSTE also provides anti-static device for all FSB 22 ball valves. Small metal ball and spring are inserted into the bottom and the side of valve stem. With anti-static device, charges caused by valve operation can be discharged and grounded, and eventually to prevent explosion by electric charges.

Certifications of Series FSB 22

API 607 4th Edition
Certified

API 607 Fire Test for Soft seated
Quarter Turn Valves

CRN
REGISTERED

Canadian Registration Number



ATEX Directive 94/9/EC
Explosive Prevention

CE Marking 0035

The whole series of ball valves are approved according to European Directive 97/23/EC.

Pressure Rating:

2000 psi WOG (PN130) for 1/4" - 2"
1000 psi WOG (PN100) sizes above
150 psi (10 bar) with saturation steam

Temperature Range:

-20°F to 350°F (-28°C to 176°C) with PTFE/RPTFE

Size Range

1/4" ~ 4" (DN8 ~ DN100)

Body Material:

ASTM CF8M, CF8, WCB
(DIN 1.4408, 1.4308, 1.0619)

End Connection:

Threaded End

Standards and Specifications

Threaded End end-to-end length meets
NPT, DIN259/2999

Valve body and end cap connections are high quality investment casting. Stainless steel material and carbon steel can be solution annealed and normalized upon requests. Body and end cap is based designed by ASME B16.34. Valve stems are blow-out proof for maximum safety and meet ASME/ANSI B16.34 specifications.

All valves are factory tested to API 598 and MSS SP-72.

Series FSB 22 are approved by API 607 4th Edition Fire- Safe Test.

Fire-Safe Approved Design

The integral fire-safe lip is designed and manufactured precisely to fit the valve ball. With the fire-safe lip, valve is able to operate after the PTFE seat has been deteriorated in fire. With the floating ball design, the valve ball and the fire-safe lip come in contact with each other and establish a metal-to-metal seal.

Valve Body Rating with Seat Material Plot

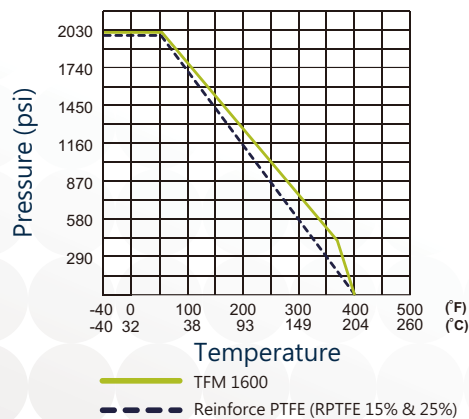

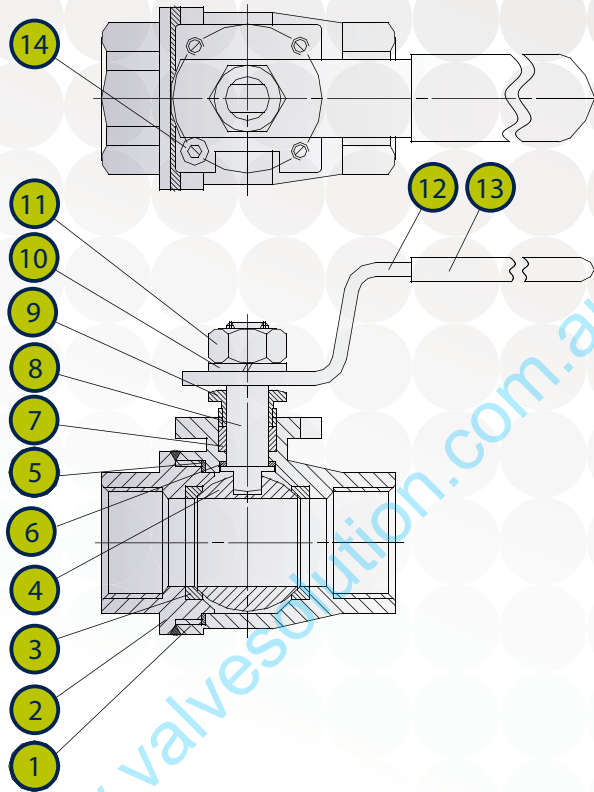

NO	PART NAME	MATERIAL
1	BODY	CF8M/ WCB
2	END CAP	CF8M / WCB
3	BALL SEAT	TFM 1600 RPTFE 15% RPTFE 25%
4	SOLID BALL	CF8M
5	BODY SEAL	PTFE / GRAPHITE
6	THRUST WASHER	GRAPHITE
7	STEM PACKING	GRAPHITE

NO	PART NAME	MATERIAL
8	STEM	SS 316
9	GLAND NUT	SS 304
10	SPRING WASHER	SS 304
11	NUT	SS 304
12	HANDLE	SS 304
13	HANDLE SLEEVE	VINYL
14	HANDLE NUT	SS 304

